

Technical Rider

CH.	INST.	MIC.	INSERT	STAND	NOTES
1	KICK	ADX-60			
2	KICK	D-6	gate	short boom	
3	SNARE top	D-2	gate		
4	SNARE bot	D-3	gate		
5	HI HAT	ADX-51			
6	RT 1	Mikro-D	gate		
7	RT 2	Mikro-D	gate		
8	FT	Mikro-D	gate		
9	OH L	ADX-51		tall boom	
10	OH R	ADX-51		tall boom	
11	BASS line	XLR			own preamp PS-1
12	BASS mic	D-4	comp.	short boom	
13	GTR 1	I-5		short boom	
14	GTR 2	I-5		short boom	
15	VOC gtr L	OM-2	comp.	tall boom	
16	VOC bass	OM-2	comp.	tall boom	
17	VOC lead	OM-5		own	own preamp PS-1
18	VOC spare	OM-5	comp.	on cable	on the floor
19	AC GTR	D.I.			
20	CD				F.O.H.
21	CD				F.O.H.
22	TC M-1				own
23	TC M-1				own
G 1	Drums		comp.		
G 2	Drums		comp.		
G 3	GTR 1		comp.		
G 4	GTR 2		comp.		

A. House Sound System**1) Console**

- Minimum 24 input channels
- Each channel at least 2-band parametric EQ plus Hi and Lo switchable cut / boost
- Insert points each channel

2) Effects/Processing

- Comp. / eight (8) channels: to ch 11, 15, 16 and 18. Groups 1 to 4
- Gate / six (6) channels: to ch 2 to 4 and 6 to 8
- One (1) Tap Delay / Roland sde 3000, TC 2290 etc.
- Two (2) Reverbs / Spx, Lexicon etc.
- One (1) 220V / 10A for own processing equipment
- CD (for intro) and MD (for recording)

3) Front Of House PA

- 15 watts per head up to 1000 capacity, 5 watts per head from 1000
- Must have subs
- Must have front fills!!!

4) Miscellaneous

- One (1) return from F.O.H. to monitor console
- Lullacry will use own mics.
- Drum riser should be at least 2 x 2 m and covered with black carpet

Technical Rider

B. Monitor system

1) We need

- Monitor console minimum 18 input channels and 6 separate output mixes.
- Two (2) wedges and/or sidefills
- Two (2) feeds from console to drums / two (2) XLR-cables
- Two (2) free frequencies (800-820 Mhz)
pick your frequency and we will use it
- Two (2) long mic stands for antennas
- **We need your monitor engineer!!! Lullacry DO NOT have their own.**

2) We have

- Own wireless IEM system, three (3) mono groups
- **GOOD FEELING**

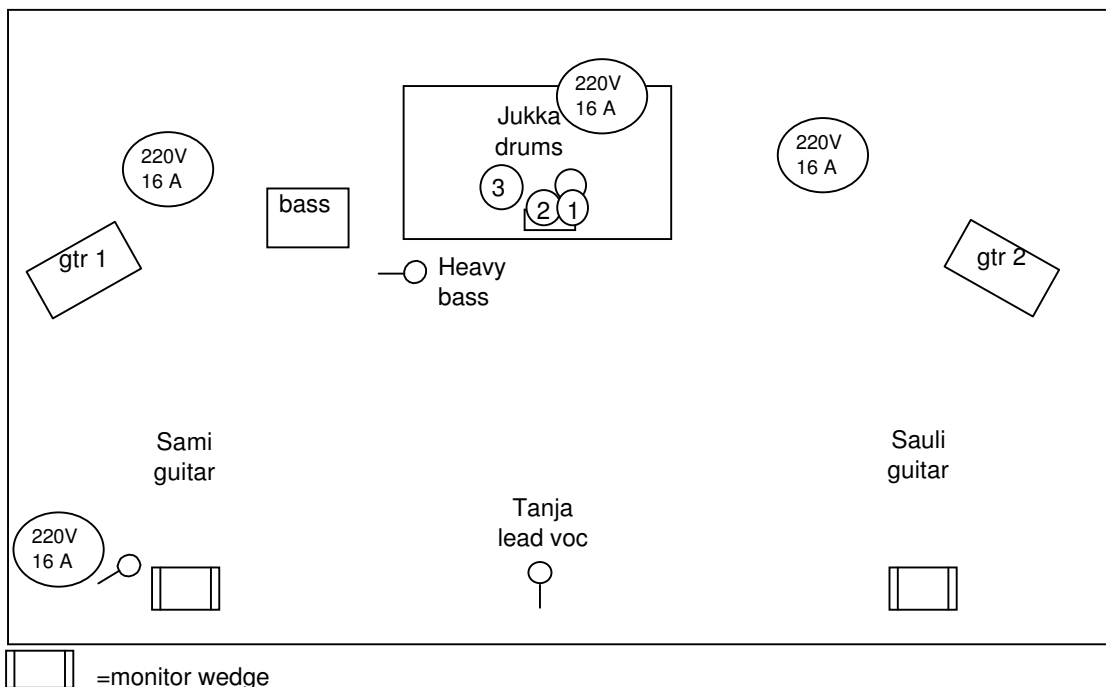

More information:

Sound Eki Saviharju Tel: +358 400 451 804 / Email: eki@lullacry.com
Lights Juho Lappalainen Tel: +358 40 903 0021 / Email: juho@lullacry.com

Please send the full details of lights straight to Juho as soon as possible! Thank You.

Booking: KING FOO ENTERTAINMENT LTD.
 Tel/fax: +358 9 694 3350 / Mobile: + 358 44 280 6699
 Email: minni@kingfoorentertainment.com

Feel free to call if you have something to ask!!! Check the latest version at www.lullacry.com